

# MD-CH Series

hydraulic edge-of-dock leveler

# BLUE GIANT®

High performance hydraulic system...

...ease of use at the touch of a button.

### Features

- Deck and lip operation provided by dual hydraulic maintenance free cylinders
- Smooth top plate transition
- Rugged remote mount single push button NEMA 4X (IP65) rated control
- Cylinders and motor pre-fitted to edge-of-dock assembly
- 1 HP motor
- Lifting hole in lip allows for quick and easy handling by installer

### Structural Integrity

- Deck and lip plates made of premium grade 50,000 psi minimum yield four-way diamond tread plate
- Heavy-duty 3/8" x 6" back beam
- One-piece, continuous front and rear hinge pins for enhanced strength and durability
- Lip bevel helps protect forklift tires and steering systems and cargo
- Two (2) molded rubber bumpers bolted onto heavy-duty steel block extensions, to help protect building and dock from damage

### Operation

- Easy to deploy, less effort "operator maintains constant control"

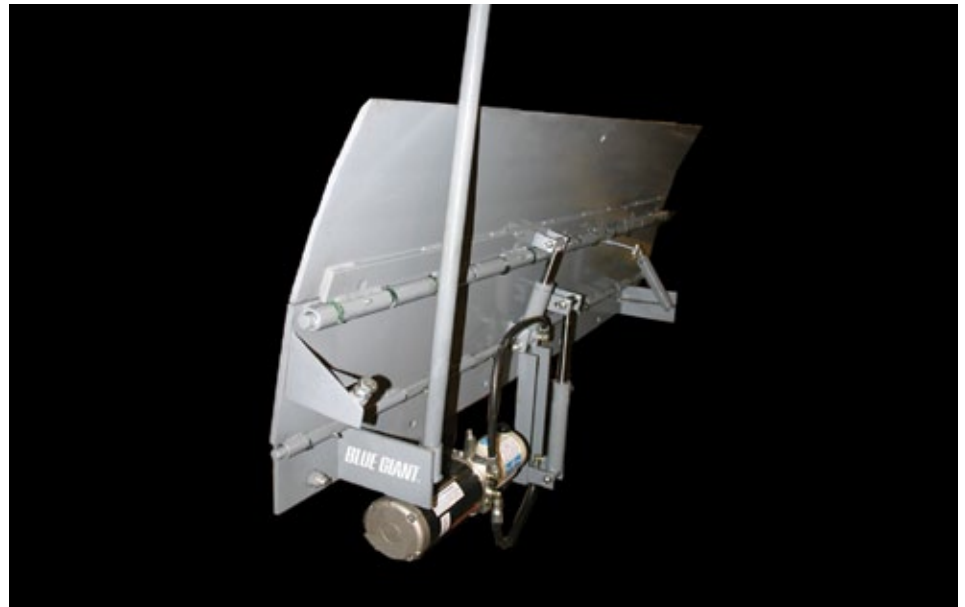

- Working range capability of 5" (127mm) above and 5" (127mm) below dock level
- Self-storing upon truck departure

### Associated products

- Vehicle restraint systems
- Light communication systems
- Wheel chocks

### Ease of service

- Single push button station
- Grease fittings to minimize operational friction
- Optional grip handle for use as maintenance stand (shown)

The MD-CH Series hydraulic edge-of-dock leveler from Blue Giant is ideally suited for applications where installation of pit levelers is not feasible or where standard fleet bed heights are serviced at the loading dock. The MD-CH Series is easily installed to the dock face providing an efficient self storing docking unit, with ease of use at the touch of a button.



Stored traffic position



Front view



Isometric view

To meet OSHA and ANSI requirements and to minimize legal/insurance issues, the use of wheel chocks (at a minimum) is mandatory anytime equipment is used at the dock to load/unload vehicles. However, with the high lifetime cost of wheel chocks and their limited effectiveness, we recommend the combined use of vehicle restraints and wheel chocks as the accepted method of securing trucks to the dock. Blue Giant provides leading technology in manual and/or power activated vehicle restraints. Maximize your employee safety while providing your company a modern, safe loading dock area.

## MD-CH Series Hydraulic Edge-of-Dock

Hydraulic edge-of-dock shall be Model \_\_\_\_\_, unit nominal size to be \_\_\_\_\_ wide x \_\_\_\_\_ long, as provided by Blue Giant Equipment Corporation, 85 Heart Lake Road South, Brampton (Ontario) Canada L6W 3K2.

### Standard construction features

- 15" (381mm) lip with bevel edge
- Dual hydraulic cylinder (deck and lip)
- NEMA4X, 3-1/2" L x 7-1/4" H x 5-1/4" P (88mm x 184mm x 133mm)
- 1 HP motor
- Welding procedure compliant with A.W.S.D.1.98 specifications
- Deck and lip constructed out of high tensile steel
- Four way diamond tread plate
- Hole in lip to help with easy handling and installation
- Two (2) molded rubber dock bumpers 10" W x 13" H x 4" D (254mm x 330mm x 102mm) mounted to heavy-duty bumper blocks

### Hydraulic operating system

Provides quiet, dependable and smooth cycling.

1. Maintain constant pressure on push button.
2. The deck raises to a vertical position and extends lip.

### Lip operation

Lip automatically extends as unit is lowered onto truck bed. Lip automatically returns to stored position upon truck departure. The length of the lip shall not be less than 15" (381mm).

### Automatic vertical compensation and travel

Unit provides float up to 5" above and below dock level.

### Automatic lateral compensation

Leveler shall have deck flex to compensate for canted (out of level) truck beds.

### Rated capacity

- 30,000 lb (13,636 kg)

### Optional Features

- 17" (432mm) lip       Flat lip  
 Comfort grip handle for use as maintenance stand

### Serviceability

- Grease fittings

### Finish and color

- Unit to be painted gray

MODEL	CAPACITY	DECK SIZE (W x L)
<input type="checkbox"/> MDC7230H	30,000 lbs (13,636 kg)	72" x 27" (1829mm x 686mm)
<input type="checkbox"/> MDC7830H		78" x 27" (1981mm x 686mm)

### Warranty

Standard one-year parts and labor warranty from date of shipment. Warranties are subject to standard limitations on liability. Please consult Blue Giant warranties at <http://www.BlueGiant.com> for full details on warranty information and product registration.

### Installation Accessories

- Approach ramps  
 Face plates  
 8" Pour-in channel

### Optional Products

- Vehicle restraint systems  
 Communication systems  
 Wheel chock systems

### Nominal Dimensions

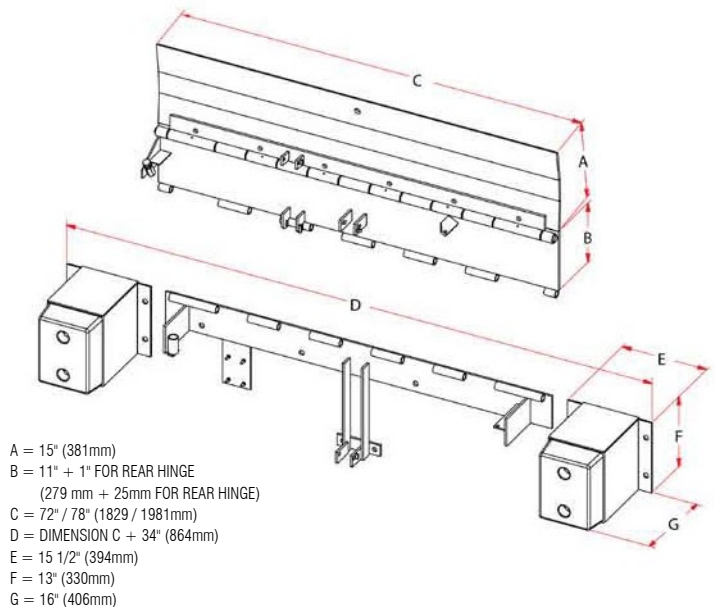

- Note:**
1. Recommend minimum 8" structural concrete embedment (pour-in) channel, installed by others. Some components are not illustrated. Mounting anchors are not included.
  2. Working range reduced by 2" when ordered with 17" lip and/or flat lip option.

