

Service Instructions and Parts List SWIVEL TRUCK LOW HEADROOM TROLLEY HOISTS

GENERAL RECOMMENDATIONS

Read the ASME B30.16 Safety Standard for Overhead Hoists. This equipment is not designed or suitable for lifting or lowering persons.

A Lockout/Tagout policy and procedure shall be implemented by the owner or user of all hoists.

Make a complete inspection of the hoist at regular and frequent intervals. See ASME B30.16 for inspection criteria and record keeping requirements.

Avoid overloading and impacting. Use only with loads within the rated capacity, and avoid sudden stops and jerking in raising or lowering. Both are dangerous and destructive and will shorten the working life of the hoist.

OPERATING THE HOIST

OPERATING ACTION: Raising or lowering a load is accomplished by gear reduction. To raise, the operator pulls on the right hand chain to rotate the hand wheel. The hand wheel then transmits the pull through the spindle, which is actually a driving pinion, to the two cluster gears (gear & pinion).

These gears with their integral pinions are mounted and revolve on fixed axles carried by the pinion cage. The pinion cage receives rotary motion from the meshing of the two cluster gears (gear and pinion) with the internal gear, which is part of the internal gear frame. The hollow load shaft is attached to the pinion cage through splines cut on the load shaft and is anchored with a setscrew and lock nut.

The load shaft then transmits rotary motion directly to the load sheaves mounted directly on the load shaft. The load sheaves pick up and carry the load chain, thereby completing the transmission of hand chain pull to the load chain.

LOAD LOCKING ACTION: There is an intermediate action in the hoist before the load lifts. When the hand wheel advances on the screw thread on the spindle, it clamps the brake discs and the ratchet tightly between the hand wheel and the spindle flange, which causes all four parts to operate as a single unit when lifting. The spindle by means of its driving pinion, transmits the pull on the hand chain into the gear reduction.

When the operator stops pulling on the hand chain, the load, in attempting to run down, causes the ratchet disc to engage a pawl, and the hand wheel and disc hub advancing on the screw threads tightens on the brake disc to prevent the load from descending. A slight pull by the operator on the left hand chain releases the pressure on the brake

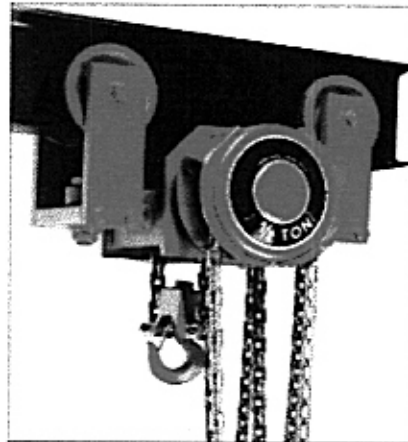

discs, permitting the brake to become a friction clutch enabling the load to descend slowly.

TRAVERSING THE HOIST: Motion along the beam on hand geared units is accomplished by imparting movement to the geared trolley wheels through the trolley hand chain and hand wheel. A trolley drive shaft connects the trolley drive pinions and the trolley hand chain wheel; then a pull on the trolley hand chain gives motion to the trolley hoist. Motion along the beam on plain units consists of shoving the load or grabbing the load chains and walking under the runway beam.

TROLLEY BRAKES: These hoists can be equipped with track clamps with a chain actuated hand wheel. This assembly consists of steel shoes with a serrated face to grip the toe of the runway beam. These shoes are actuated through a track clamp screw that has a left and right hand thread on the same shaft. The shaft is caused to rotate by a track clamp hand wheel that carries a special hand chain. A pull on the hand chain thus causes the shoes to engage or back away from the toe of the monorail.

MAINTENANCE PROCEDURE

LUBRICATION

BRAKE: It should be immediately noted in connection with lubrication of the hoist that the brake requires none at any time. However, while it is preferable not to lubricate it, the brake will operate efficiently regardless of lubrication on its surfaces. It is advisable, though, to clean the brake surfaces in the course of each inspection.

BALL AND NEEDLE BEARINGS: Lubricate with a good grade of lithium base grease recommended for anti-friction bearings, approximately A.S.T.M. working penetration 265-295, (*) NLGI No. 2.

Note : Lubrication and Maintenance Procedures continued on back page

ORDERING INFORMATION AND PARTS LIST

Recommended Procedure for Ordering Parts:

To insure prompt service, each repair parts purchase order must include the following information:

1. Quantity required
2. Part No. (see Parts List)
3. Description (see parts List)
4. Hoist capacity
5. Hoist serial no.
6. Your complete address, and complete address of shipping destination

If this nameplate has been removed or defaced, give size and type of I-beam on which the hoist operates.

If in doubt about any required parts information, return the part or parts to be replaced to the factory, transportation prepaid. Attach a tag to each part, giving as much information as available, your complete name and address, and your purchase order number.

The serial number of each hoist may be found on the small aluminum nameplate mounted on its side plate.

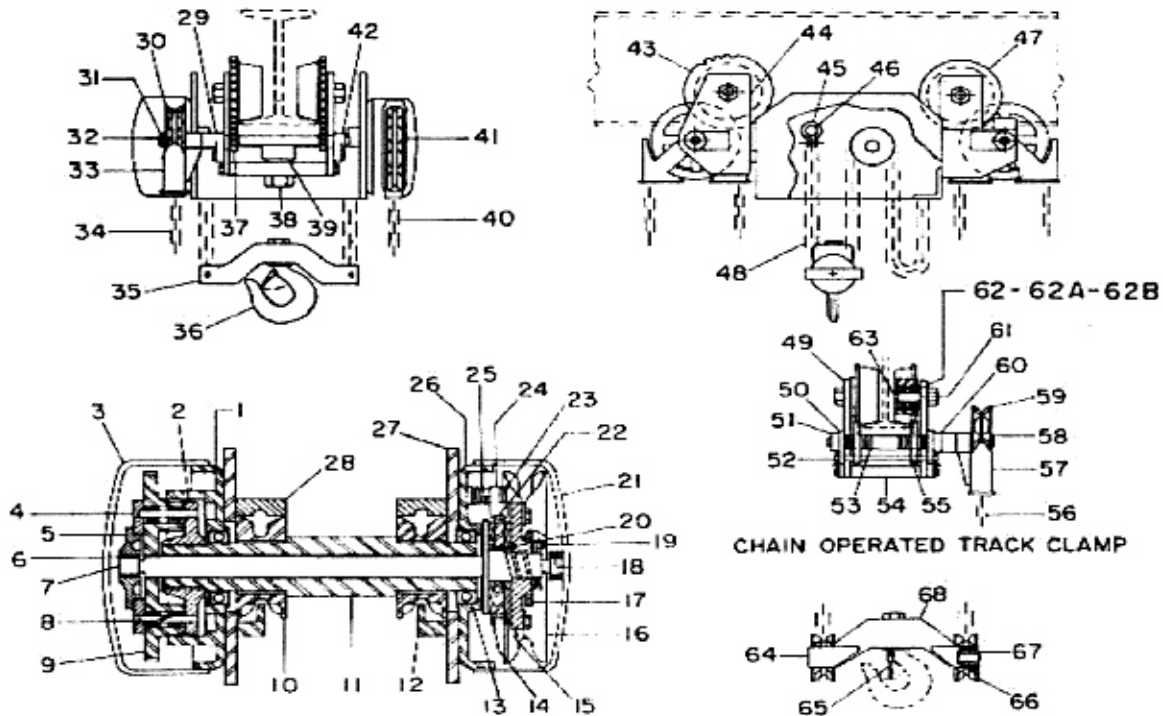

On some capacities items 10 and 11 are combined into one piece

REF NO.	PART NO.	DESCRIPTION	QUANTITIES PER CAPACITY IN TONS				
			1/2 & 3/4	1	1 1/2 & 2	3 & 4	5 & 6
1	9620-G	Internal Gear Frame	1	1	1	1	1
2	921	Pinion Cage	1	1	1	1	1
3	930	Gear Cover	1	1	1	1	1
4	919	Gear and Pinion Shaft	2	2	2	2	2
5	959	Pinion Cage Bearing Block w/bushing	1	1	1	1	1
6	906	Bronze Bushing for 959	1	1	1	1	1
7	9618	Spindle	1	1	1	1	1
8	922	Needle Bearing For Gear and Pinion	4	4	4	4	4
9	927	Gear and Pinion	2	2	2	2	2
10	9629	Load Sheave	2	2	2	2	2
11	9674	Splined Load Shaft	1	1	1	1	1
12	9624	Stripper	2	2	2	2	2
13	960	Load Shaft Bearing	2	2	2	2	2
14	934	Brake Disc (Pair)	1	1	1	1	1
15	916	Handwheel Threaded Insert	1	1	1	1	1
16	928	Handwheel	1	1	1	1	1
17	925	Adjustable Check Ring	1	1	1	1	1
18	903	Bronze Bushing in Handwheel Cover	1	1	1	1	1
19	909	Cotter Pin	1	1	1	1	1
20	907	Ratchet Bushing for 935 Ratchet	1	1	1	1	1

BEATON INDUSTRIAL, INC.
 6083 Trenton Rd.
 Utica, NY 13502
 (315) 797-9346

REF NO.	PART NO.	DESCRIPTION	QUANTITIES PER CAPACITY IN TONS				
			1/2 & 1/2	1	1 1/2 & 2	3 & 4	5 & 6
21	968	Handwheel Cover with 903 Bushing	1	1	1	1	1
22	935	Ratchet with 907 Bushing	1	1	1	1	1
23	908	Pawl Snap Ring	1	1	1	1	1
24	923	Pawl	1	1	1	1	1
25	910	Pawl Spring	1	1	1	1	1
26	9620-H	Handwheel Side Frame	1	1	1	1	1
27	9685	Hoist Frame	1	1	1	1	1
28	9605	Chain Guide	4	4	4	4	4
29	906-A	Handwheel Shaft Support (Long)	1	1	1	1	1
30	9120	Trolley Handwheel	1	1	1	1	1
31	9187	Trolley Drive Shaft Snap Ring	1	1	1	1	1
32	9611	Trolley Drive Shaft	1	1	1	1	1
33	9121	Trolley Handwheel Swinging Guard	1	1	1	1	1
34	937	Trolley Drive Hand Chain (Specify drop)	1	1	1	1	1
35	9652-1	Bottom Crosshead (Unreeved)	1	1	-	-	-
36	9640	Bottom Load Hook and Nut	1	1	1	1	1
37	911A	Pinion Gear	2	2	2	2	2
38	9658	Swivel Bolt and Nut	2	2	2	2	2
39	9681	Cross Piece Bushing or Bearing	2	2	2	2	2
40	937	Hoist Hand Chain (Specify drop)	1	1	1	1	1
41	914	Hand Chain Guide	2	2	2	2	2
42	906-B	Handwheel Shaft Support (Short)	1	1	1	1	1
43	9108	Geared Trolley Wheel	2	2	2	2	2
44	9683-G	Geared Trolley Side Plate	2	2	2	2	2
45	9293	Dead End Bale	-	-	2	2	2
46	9689	Dead End Stud	-	-	2	2	2
47	9109	Plain Trolley Wheel, Geared unit Qty. ()	4(2)	4(2)	4(2)	4(2)	4(2)
48	938	Load Chain (Specify lift)	2	2	2	2	2
49	9683	Plain Trolley Side Plate, Geared unit Qty. ()	4(2)	4(2)	4(2)	4(2)	4(2)
50	9153	Track Clamp Side Plate (Optional)	2	2	2	2	2
51	906-B	Track Clamp Screw Support (Short)	1	1	1	1	1
52	9152	Track Clamp Guide Pin	1	1	1	1	1
53	9151	Track Clamp Screw	1	1	1	1	1
54	9682	Cross Piece (Specify track size)	2	2	2	2	2
55	9150	Track Clamp Jaw Pair (LH and RH)	1	1	1	1	1
56	937	Track Clamp Hand Chain (Specify drop)	1	1	1	1	1
57	9121	Track Clamp Handwheel Swinging Guard	1	1	1	1	1
58	9187	Track Clamp Screw Snap Ring	1	1	1	1	1
59	9120	Track Clamp Handwheel	1	1	1	1	1
60	906-A	Track Clamp Screw Support (Long)	1	1	1	1	1
61	9110	Wheel Axle with Spacer(s)	4	4	4	4	4
62	9107	Wheel Ball Bearing	8	8	8	-	-
62A	9116	Tapered Bearing Cone	-	-	-	8	8
62B	9117	Tapered Bearing Cup	-	-	-	8	8
63	9112	Bearing Adjustment Nut	-	-	-	4	4
64	9688	Bottom Block Sheave Guard	-	-	2	2	2
65	H/L	Hook Latch	1	1	1	1	1
66	9656	Idler Sheave with Bushing	-	-	2	2	2
67	9125	Bushing for 9656	-	-	2	2	2
68	9652-2	Bottom Crosshead (Reeved)	-	-	1	1	1
SPECIAL FASTENERS (NOT ILLUSTRATED)							
	998	Gear (930) and Handwheel (968) Cover Screw	8	8	8	8	8
	999	Hand Chain Guide (914) Screw	8	8	8	8	8

CHAIN SPECIFICATIONS

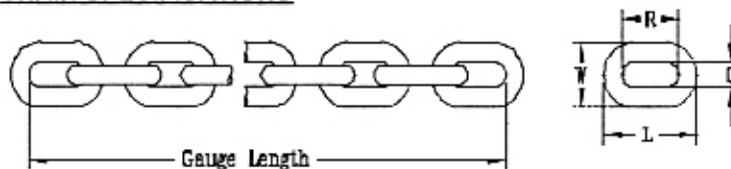

For Parts Contact:

Chester Hoist
 Phone : (330) 424-7248
 Fax: (330) 424-7248
 E-mail:
sales@chesterhoist.com

Use and Description	Part No.	Chain Size (wire dia.)	C	W	R	L	Gauge Length	Net Weight
HAND CHAIN	C-937	1/4"	.378	.878	1.048	1.548	19 links: 20.406"	.50 lbs/ft.
LOAD CHAIN:								
1/4 thru 2 Ton	C-38-1/2	9/32"	.313	.876	.794	1.357	25 links: 19.925"	.75 lbs/ft.
3 thru 6 Ton	C-38-1/2A	9/32"	.313	.876	.794	1.357	25 links: 19.925"	.75 lbs/ft.

BEATON INDUSTRIAL, INC.
 6083 Trenton Rd.
 Utica, N.Y. 13502
 (315) 797-9346

LUBRICATION (continued from front page)

GEARS: Use a high-grade non-corrosive extreme pressure lithium base grease, NLGI No. 2.

LOAD CHAIN: The usable life of a load chain can be appreciably increased by lubricating the chain at frequent intervals. Unlubricated chain wears rapidly from friction with the pocket wheel as well as with its own inter-links. Thoroughly clean chain with an oil solvent and relubricate by dipping in light oil (S.A.E. 10 or 20). Wipe off excess oil before reapplying chain to the hoist.

TROLLEY WHEELS: Ball check hydraulic grease fittings are provided on each trolley wheel or axle. Lubricate with a good grade of lithium base grease, NLGI No. 2.

(*) NLGI - National Lubricating Grease Institute

RE-ASSEMBLY: Should it ever become necessary to dismantle the hoist, extreme care must be exercised in reassembling the cluster gears in the internal gear frame. Punch marks on the pinion gears must be nearest to and in a direct line with each other to mesh properly in this planetary gear system.

INSPECTING THE HOIST

MAKE A COMPLETE INSPECTION of the hoist at regular and frequent intervals. See ASME B30.16 for inspection criteria and record keeping requirements.

1. Inspect bottom hook for excessive wear or opening. Examine the bolt attaching the load chain to the bottom block or top dead and shackle for damage or loosened locking nut. If hooks appear to be badly stretched or worn, replace with new ones.
2. Examine the load chain for excessive wear, particularly at its inter-link contacting points. Measure the pitch or gauge length of the chain, and compare with the standard dimensions as shown above. An increase in pitch will indicate that the

chain has been elongated or that excessive wear has taken place. Elongation generally causes harmful wear on the pockets of the load sheave. Load sheave pockets should be examined for wear and improper engagement with the load chain. Any tendency of the load chain to ride up out of sheave pockets while under rated load will indicate faulty chain engagement. Replace obviously worn or stretched chain. Do not anneal load chain furnished with or for this hoist. It has been heat-treated and will not work-harden. It will wear well if kept well lubricated. Replace the load sheave when its pockets become excessively worn. If the sheave is replaced, do not use stretched or badly worn chain and risk damaging the new sheave pockets.

3. Test the brake mechanism, by operating the hoist under load, to determine if the brake is holding the load at all positions. If the brake fails to hold properly, brake parts should be disassembled and thoroughly cleaned. Check for excess wear or other damage, then reassemble and again test under load. Replace brake assembly washers, pawl or pawl spring if badly worn or damaged.
4. Remove the gear cover and inspect all gearing. Check all gear teeth for excess wear or other damage.
5. Inspect trolley wheels, visually, for damage or wear. Push-pull and hand-g geared trolleys should also be checked for proper ease of traverse along the supporting track.

CAUTION: Make all necessary replacements immediately

NOTE: A hoist in which load suspension parts have been altered, replace or repaired should be load tested at 100% of rated capacity per ASME B30.16.

DO'S AND DON'TS FOR SAFE OPERATION

DO'S

Read ASME B30.16 safety standard for overhead hoists

1. CHECK lubricant before operating the hoist
2. EXAMINE hoist before each shift. CHECK for damaged hooks or chains, also make sure the hoist is properly secured. Make sure your hoist is kept clean and well lubricated.
3. CHECK daily the chain for improper seating, twisting, kinking, wear or other defects before operating the hoist. If these are not checked, the chain may break under a normal load.
4. BE SURE there are no objects in the way of a load or hook when moving the hoist on the trolley.
5. MAKE SURE a load clears neighboring stockpiles or machinery when raising or lowering the load.
6. CENTER hoist unit over the load before lifting.
7. AVOID swinging of load or load hook when traveling the hoist.
8. PROPERLY secure outdoor hoist when unattended.
9. KEEP load block above head level when not in use.
10. BE SURE the sling is properly seated in the saddle of the hook. Tip loading leads to spreading and possible failure. Hook latch should not support any part of the load.
11. DO lift a load only a few inches then check load balance and brake operation before proceeding.

DON'TS

1. NEVER lift a load with hoist until all personnel are clear.
2. DO NOT allow any unqualified personnel to operate hoist. See ASME B30.16 for operation training requirements.
3. AVOID collisions or bumping of hoists.
4. DO NOT transport load over personnel.
5. NEVER carry personnel on the hook or the load.
6. DO NOT operate hoist if you are not physically fit to do so.
7. NEVER pick up a load beyond the capacity appearing on the hoist.
8. DO NOT tamper with any parts of the hoist unless you are a qualified maintenance man.
9. NEVER use the hoist chain as a sling.
10. DO NOT use chain as ground for welding. NEVER touch the welding electrode to the chain.
11. DO NOT divert attention from load while operating hoist.
12. DO NOT leave a load suspended in the air at the end of a work shift, or for extended periods of time and DO NOT leave a load unattended during regular working hours.
13. DO NOT tip or "point" load a hook.
14. DO NOT operate a hoist in need of adjustment or repair.
15. DO NOT operate a hand hoist with power or more than one operator.
16. DO NOT operate a hoist that has been tagged out of service.

BEATON INDUSTRIAL, INC.
6083 Trenton Rd.
Utica, N.Y. 13502
(315) 797-9346