

Acco® WRIGHT®

end trucks
product series 430
top running
single girder

instruction
and parts
manual

WARNING

This equipment should not be installed, operated or maintained by any person who has not read all the contents of these instructions. Failure to read and comply with these instructions or any one of the limitations noted herein can result in serious bodily injury and/or property damage.

Only competent engineering and fabrication personnel, familiar with standard crane design and fabrication practices, should be employed to design and fabricate cranes using this equipment because of the necessity of properly interpreting these instructions and for the purposes of determining appropriate compatible equipment and product applications. Acco disclaims any responsibility for the quality of design and workmanship employed in the design and fabrication of a crane or other system using this equipment or the sufficiency of the structure in which and to which this equipment is to be installed or the sufficiency of the crane or system to sustain any particular load that may be imposed upon it. Contact Acco Chain & Lifting Products for additional information if necessary.

There are no other warranties which extend beyond the description on the Order Acknowledgment and as it may apply to the specifications provided in this publication. THE IMPLIED WARRANTIES OF MERCHANTABILITY AND FITNESS FOR A PARTICULAR PURPOSE ARE EXCLUDED. Acco shall in no event be liable for any special, direct, indirect, incidental or consequential damages to anyone beyond the cost of replacement of the goods sold hereby.

BEATON

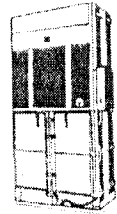
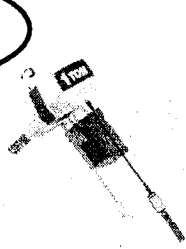

OVERHEAD EQUIPMENT
HOISTS

ERGNOMICS

HYDRAULIC
BALERS

AIR CURTAINS
BALERS/COMPACTORS
BELOW HOOK
BENCHES/CARTS/TOOLS
BRIDGE CRANES
CABINETS
CASTERS/WHEELS
CONTAINERS/WHEELS
CONVEYORS
DOCK EQUIPMENT
ENGINEERED SYSTEMS
FLOOR MATTING
OVERHEAD DOORS
DRUM HANDLING
FLAMMABLE CABINETS
FLOW RACK
GANTRY CRANES
GUARD RAIL
HAND TRUCKS
HIGH SPEED ROLL UP DOORS
HOISTS
INDUSTRIAL BATTERIES
INDUSTRIAL VACUUMS
INPLANT OFFICES
INSTALLATIONS
JIB CRANES
LAYOUTS/DESIGNS
LIFTERS
LIFT TABLES
LOCKERS
MACHINE MOVERS
MESSAGE TRANSFER
MEZZANINES
MODULAR DRAWER CABINETS
MOBILE AISLE STORAGE
OFFICE FURNITURE
OVERHEAD LIFTING EQUIPMENT
PALLETS
PALLET TRUCKS
PERSONNEL LIFTS
SAFETY LADDERS
SCALES
SELF DUMPING HOPPERS
SERVICE/SERVICE CONTRACTS
STACKER CRANES
STORAGE PRODUCTS
STRETCH WRAP MACHINES
SHIPPING SUPPLIES
TABLES
TOILET PARTITIONS
AND MANY MORE...

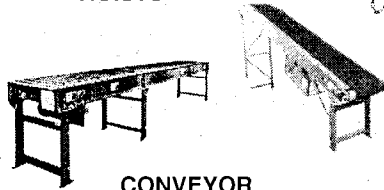

CONVEYOR

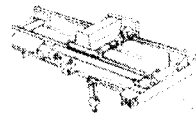

BRIDGE CRANES

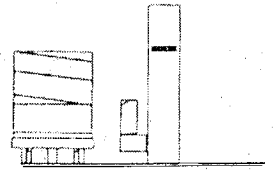

WRAPPERS

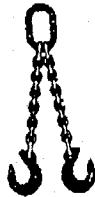

SLINGS

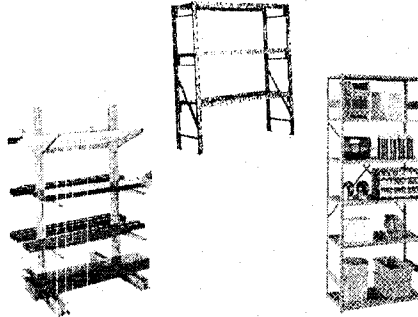

RACKING/SHELVES

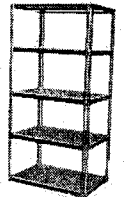
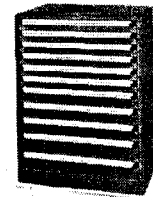
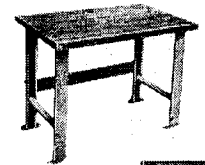

Beaton Industrial, Inc.

6083 Trenton Road
Utica, NY 13502

Ph. 1-800-724-4052 (N.Y. Only)

Ph. 1-315-797-9346

Fax 1-315-797-9321

e-mail:

beaton@deamscape.com

Web:

www.BeatonIndustrial.com

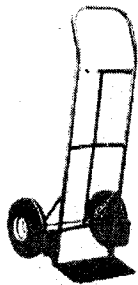

HAND TRUCKS

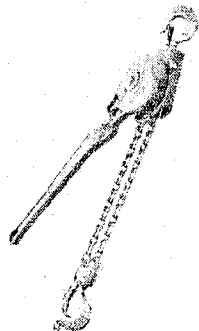

PULLERS

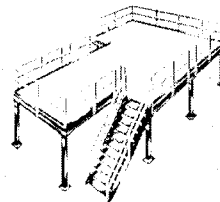

MEZZANINES

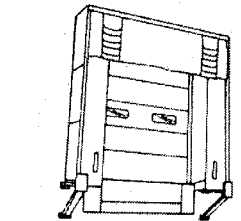

DOCKS, DOORS, SEALS

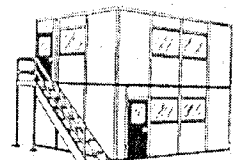

INPLANT OFFICES

HOIST AND CRANE REPAIR CENTER
INSTALLATIONS, PARTS, SERVICE
DESIGN/LAYOUT/ FABRICATIONS,
APPLICATION STUDIES
CRANE & HOIST INSPECTIONS



CASTERS

"Specializing In Materials Handling"

CAUTION

These general instructions deal with the normal installation, operation, and maintenance situations encountered with the equipment described herein. The instructions should not be interpreted to anticipate every possible contingency or to anticipate the final crane or system configuration that uses this equipment.

This manual includes instructions and parts information for a variety of crane component equipment. Therefore, all instructions and parts information may not apply to any one type or size of equipment. Disregard those portions of the instructions which do not apply.

Use only Acco authorized replacement parts in the service and maintenance of this equipment.

WARNING

Equipment described herein is not designed for and should not be used for lifting, supporting, or transporting humans.

Equipment described herein should not be used in conjunction with other equipment unless necessary and/or required safety devices applicable to the system, crane, and application are installed by the crane builder or user.

Modifications to upgrade, rerate, or otherwise alter this equipment shall be authorized only by the original equipment manufacturer or qualified professional engineer.

Equipment described herein is only for use in the design and manufacture of cranes. Additional equipment or devices may be required for the crane to comply with applicable crane design and safety standards. The crane designer, crane manufacturer, or user is responsible to furnish these additional items for compliance. Refer to ASME B30.17 for top-running single girder cranes.

Quantity and location of bolts furnished with these end trucks for attaching the bridge girder to the end trucks are of a general nature only. Actual quantity and location of bolts or other attachment methods must be determined by the crane designer or crane manufacturer to result in a connection that will structurally sustain the actual loads caused by the design and application of the crane in accordance with acceptable crane design standards and specifications. The crane designer or crane manufacturer must also determine if corner bracing or other bracing means will be required.

Electrical equipment described herein is designed and built in compliance with ACCO's interpretation of ANSI/NFPA 70 (National Electrical Code). The crane designer, crane manufacturer or user is responsible to assure that the installation and associated wiring of these electrical components is in compliance with ANSI/NFPA 70, and all applicable Federal, State and Local Codes.

Failure to read and comply with any one of the limitations noted herein can result in serious bodily injury and/or property damage.

DANGER

HAZARDOUS VOLTAGES ARE PRESENT IN THE CONTROL BOX, OTHER ELECTRICAL COMPONENTS, AND CONNECTIONS BETWEEN THESE COMPONENTS.

Before performing ANY mechanical or electrical maintenance on the equipment, de-energize (disconnect) the main switch supplying power to the equipment; and lock and tag the main switch in the de-energized position.

Only trained and competent personnel should inspect and repair this equipment.

END TRUCK KITS

PRODUCT NUMBER	CAPACITY	MAX. SPAN	TYPE	RAIL SIZE	MAX. TRUCK LOAD (a)	TRUCK WEIGHT (b)	Each Push Type Kit includes: (2) End Trucks (1) Instruction and Parts Manual Each Gear Type Kit includes: (2) End Trucks (2) Pinions (2) Keys (2) Retaining Rings (1) Instruction and Parts Manual
4300600	3 Ton	35 Ft.	Push	40#	11,000 lbs.	580 lbs.	
4300610	3 Ton	50 Ft.	Push	40#	13,000 lbs.	667 lbs.	
4300620	3 Ton	35 Ft.	Gear	40#	11,000 lbs.	587 lbs.	
4300630	3 Ton	50 Ft.	Gear	40#	13,000 lbs.	673 lbs.	
4300640	5 Ton	35 Ft.	Gear	40#	16,000 lbs.	582 lbs.	
4300650	5 Ton	50 Ft.	Gear	40#	18,000 lbs.	669 lbs.	
4300660	10 Ton	35 Ft.	Gear	40-80#	28,600 lbs.	839 lbs.	
4300670	10 Ton	50 Ft.	Gear	40-80#	30,900 lbs.	954 lbs.	

(a) Calculated Truck Loads must include:

1. Live load impact allowance of 1/2% of lifting speed in FPM, but not less than 15% when used with an electric powered hoist.
2. Dead load impact allowance of 10% (includes weight of crane, hoist, and attachments.)

(b) Truck Weight is per pair of end trucks.

BUMPER KITS

PRODUCT NUMBER	MAXIMUM SPAN	SPEED	Each Bumper Kit includes: (4) Bumpers (4) Washers (4) Lockwashers (4) Nuts
6450010	50 Ft.	50 & 75 FPM	
6450010	35 Ft.	110 FPM	
6450020	50 Ft.	110 FPM	

CAPACITY PLATES

PART NUMBER	DIMENSIONS
63878	4.50" x 24"
63879	7.75" x 42"
Quantity (2) Plates needed per crane.	

END TRUCK DIMENSIONS

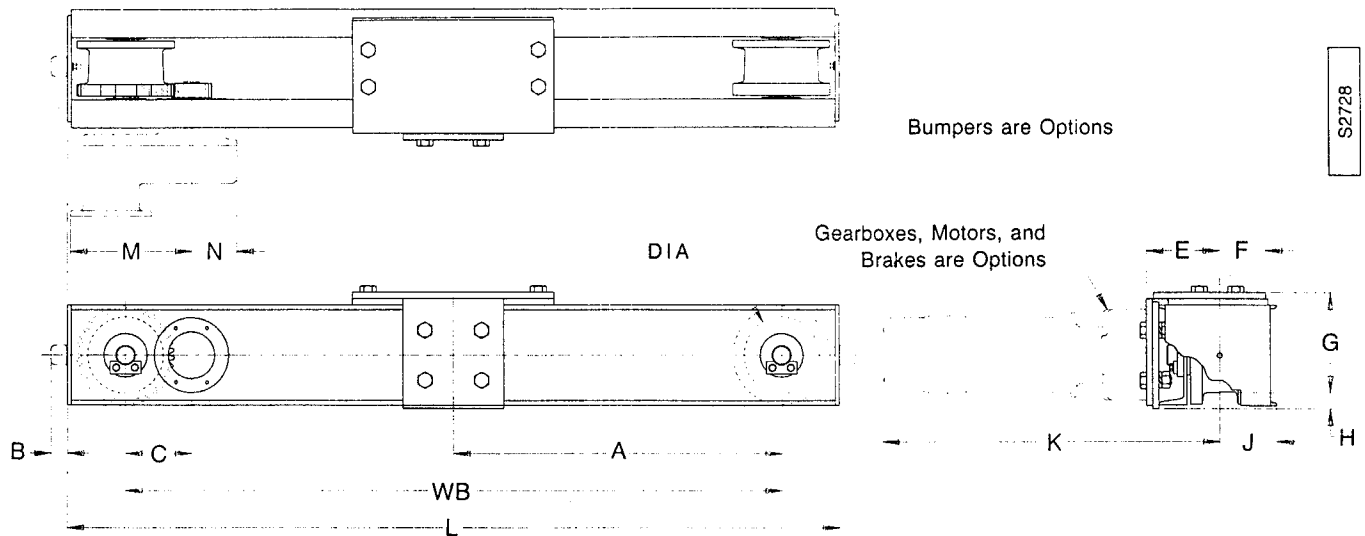

PRODUCT NUMBER	L	WB	A	C	DIA.	E	F	G	H	J	M	N
4300600	62.0"	52.5"	26.25"	N/A	6"	5.88"	3.69"	8.00"	1.25"	4.56"	N/A	N/A
4300610	84.5"	75.0"	37.50"	N/A	6"	5.88"	3.69"	8.00"	1.25"	4.56"	N/A	N/A
4300620	62.0"	52.5"	26.25"	5.32"	6"	5.88"	3.69"	8.00"	1.25"	4.56"	9.85"	3.63"
4300630	84.5"	75.0"	37.50"	5.32"	6"	5.88"	3.69"	8.00"	1.25"	4.56"	9.85"	3.63"
4300640	62.0"	52.5"	26.25"	5.32"	6"	5.88"	3.69"	8.00"	1.25"	4.56"	9.85"	3.63"
4300650	84.5"	75.0"	37.50"	5.32"	6"	5.88"	3.69"	8.00"	1.25"	4.56"	9.85"	3.63"
4300660	64.0"	52.5"	26.25"	6.32"	8"	6.56"	4.00"	10.00"	1.25"	5.25"	9.85"	3.63"
4300670	86.5"	75.0"	37.50"	6.32"	8"	6.56"	4.00"	10.00"	1.25"	5.25"	9.85"	3.63"

B	Product No. K6450010 Bumper Kit	1.34"
	Product No. K6450020 Bumper Kit	1.66"

K	3 & 5 Ton - Single Speed Drives	26.81"
	3 & 5 Ton - Two Speed Drives	28.31"
	10 Ton - Single Speed Drives	27.13"
	10 Ton - Two Speed Drives	28.63"

MAINTENANCE AND INSPECTION PROCEDURES

Before maintenance or inspections are performed on a crane, crane runway, or crane runway conductors, the following precautions shall be taken as applicable. Top-running single girder cranes shall be inspected and tested in accordance with the intervals and requirements of ASME B30.17, Safety Standard for Overhead and Gantry Cranes (Top Running Bridge, Single Girder, Underhung Hoist).

1. The crane to be repaired or inspected shall be run to a location where it will cause the least interference with other cranes and operations in the area.
2. If a load is attached to the crane, it shall be landed.
3. All controllers shall be placed in the off position.
4. The main switch (crane disconnect) shall be de-energized. Lock and tag the main switch in the de-energized position in accordance with ANSI Z244.1.
5. Warning signs and barriers shall be utilized on the floor beneath the crane where overhead maintenance and inspection work creates a hazard.
6. If the runway remains energized, stops or a signal person(s), located full-time at a visual vantage point for observing the approach of an active crane(s), shall be provided to prohibit contact by the active crane(s) with the idle crane; with persons performing maintenance or inspections; and with equipment used in performing the maintenance or inspection.
7. A guard or barrier shall be installed between adjacent runways for the length of the established work area to prevent contact between persons performing maintenance or inspection and a crane on the adjacent runway.

WHEEL OR WHEEL BEARING REPLACEMENT

1. Perform steps outlined in MAINTENANCE AND INSPECTION PROCEDURES above.
2. Block crane on runway as not to allow any horizontal travel. Support the end truck at the corner where the wheel is to be removed.
3. Remove the axle keeper plate by removing the bolts and lockwashers.
4. Slide the axle out of the wheel and end truck frame.
5. Lift the wheel up out of the end truck, being careful the bearings do not drop out of the wheel.
6. Replace the bearings and/or wheel. Reassemble the bearings into the wheel, checking that the bearing is lubricated as outlined in LUBRICATION section of this manual.
7. Lower the wheel into the end truck, making sure the large diameter of the wheel tread faces the axle keeper plate side of the end truck. (The large diameter of the wheels should be facing the center of the crane.) See diagram below.
8. Insert the axle, and reinstall the keeper plate with the bolts and lockwashers.
9. Remove all blocks, supports, and tools from the runway and crane before operating.

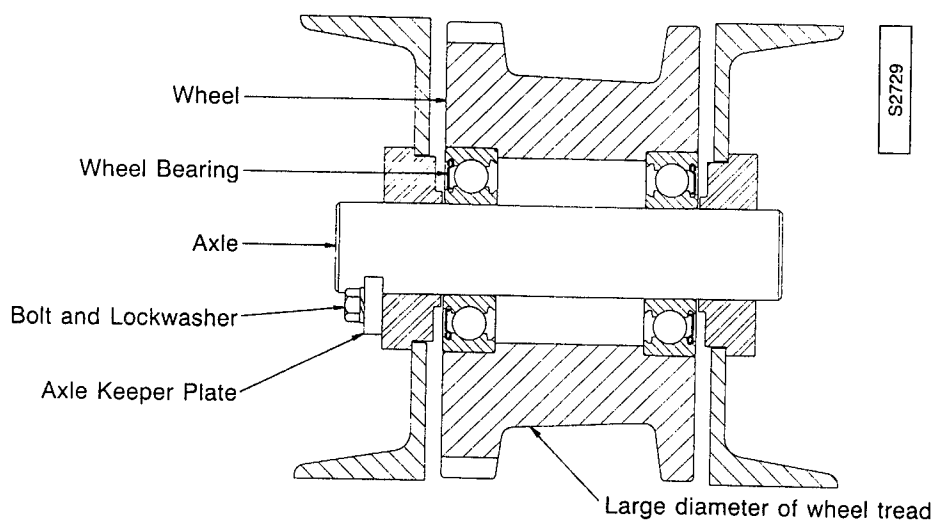

END TRUCK CROSS SECTION

LUBRICATION

1. Wheel bearings are pre-lubricated and sealed or shielded for operation in ambient temperatures between 0°F and 104°F, and in atmospheres reasonably free from dust, moisture, and corrosive fumes. For other operating conditions, contact Acco Chain and Lifting Products. Check wheel bearings at regular intervals and, if necessary, pack with NGLI No. 2 grease.
2. Wheel gears and pinions should be kept well coated with NGLI No. 2 grease as required.

CRANE OPERATION SAFETY PROCEDURES

1. The operator shall not engage in any practice which will divert the operator's attention while actually engaged in operating the crane.
2. The operator is responsible for lifts and operations under the operator's direct control. The operator shall obey any stop signal during the lifts.
3. The operator shall be familiar with the safety practices of ANSI B30.17. The operator shall also be familiar with the equipment and report the need for any repairs or adjustments to the appointed responsible person and to the next operator upon changing shifts (if corrective action has not been completed).
4. Contacts with runway stops or other cranes shall be made with caution.
5. All controls, brakes, and limit switches of a crane shall be tested by the operator before beginning a new shift. If anything does not operate properly, it shall be adjusted or repaired before operations begin.
6. The crane shall not be loaded in excess of its rated load except for test purposes or planned engineered lifts as specified in ANSI B30.17.
7. The load shall be attached to the load block hook by means of slings or other devices.
8. Before lifting a load, the operator shall ascertain that:
 - the hoist chain or hoist rope is free from kinks or twists and is not wrapped around the load;
 - the hoist ropes are not twisted around each other and are seated in the drum grooves and sheaves;
 - the load, sling, or lifting device is seated in the bowl of the hook;
 - the load is secured, balanced, and positioned in the hook, sling, or lifting device;
 - the hook is brought over the load for a true vertical lift, to minimize swinging;
 - the load, sling, attachments, and load block will clear all obstacles;
 - there is no one on the hook or load.
9. During lifting and carrying a load, the operator shall ascertain that:
 - there is no sudden acceleration or deceleration of the moving load;
 - the load, sling, attachments, and load block do not contact any obstructions;
 - the load is not carried over people.
10. The operator shall not leave the controls while the load is suspended over an area accessible to people unless specific precautions have been instituted and are in place.
11. The load shall not be lowered below the point where two wraps of rope remain on each anchorage of the hoisting drum unless a lower limit device is provided, in which case no less than one wrap shall remain.
12. The load block should be lifted above head level for storage when the crane is not in use.

END TRUCK PARTS

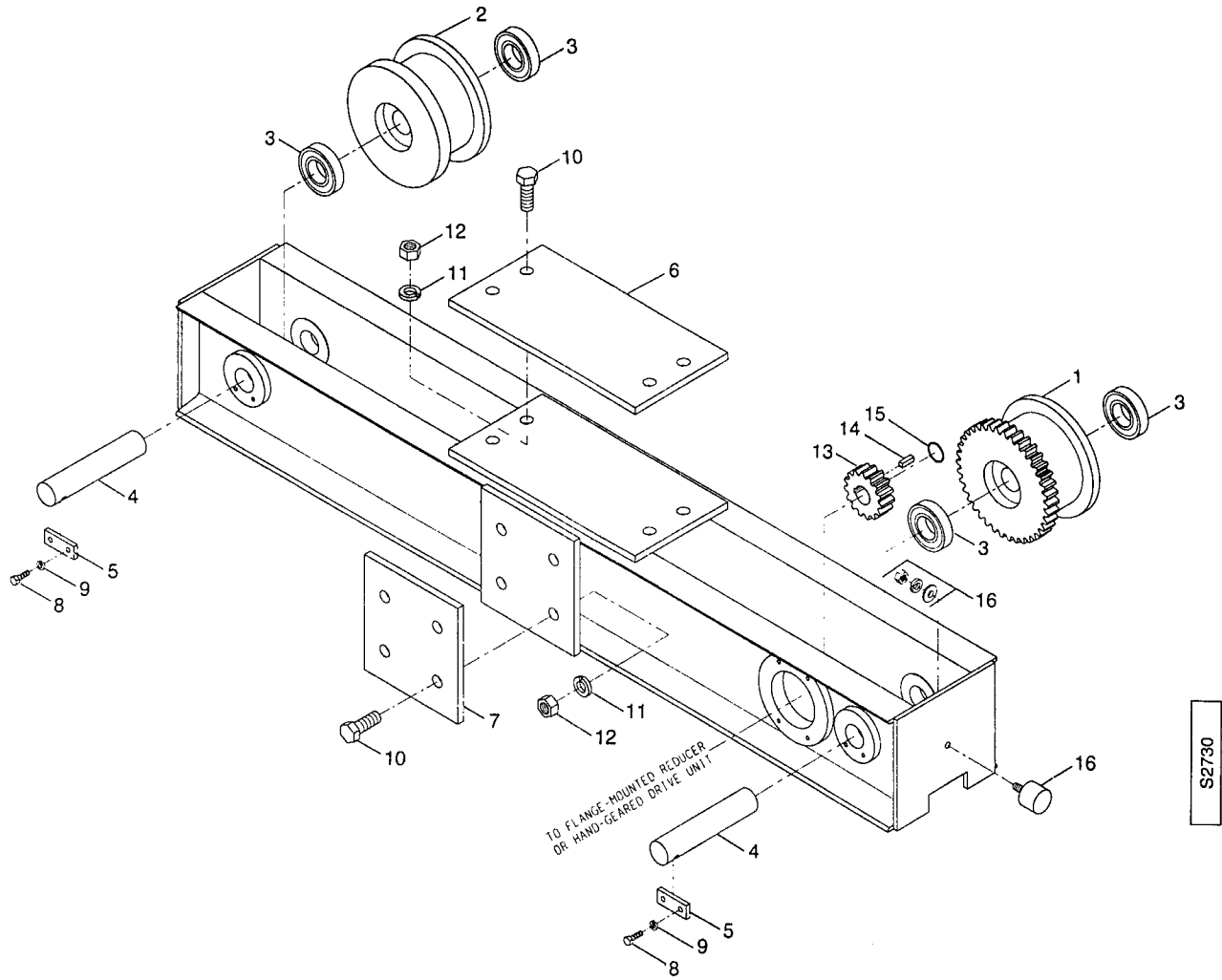

3, 5, & 10 TON END TRUCK PARTS

ITEM	DESCRIPTION	3 TON	5 TON	10 TON	QTY.
1	Geared Wheel	69343	69345	69347	1
2	Plain Wheel	69342	69344-02	69346-02	1
3	Bearing	PA7346	PA7347	PA7348	4
4	Axle	69348	69348	69349	2
5	Keeper Plate	69350	69350	69350	2
6	Girder Mounting Plate	69370	69370	69371	1
7	Clip Mounting Plate	69374	69374	69375	1
8	Bolt 5/16-18 x 1	35-5-16	35-5-16	35-5-16	4
9	Lockwasher 5/16	17-5C	17-5C	17-5C	4
10	Bolt 3/4-10 x 2	35-12-32	35-12-32	35-12-32	8
11	Lockwasher 3/4	17-12C	17-12C	17-12C	8
12	Nut 3/4-10	22-12	22-12	22-12	8
13	Pinion	51291	51291	51291	1
14	Key	68290	68290	68290	1
15	Retaining Ring	PA3269	PA3269	PA3269	1
16	Bumpers (optional)	See Right	See Right	See Right	2

Note: Quantities shown are for a single end truck.

3 TON PUSH END TRUCK PARTS

ITEM	DESCRIPTION	PART NO.	QTY.
2	Plain Wheels	69342	2
3	Bearing	PA7346	4
4	Axle	69348	2
5	Keeper Plate	69350	2
6	Girder Mounting Plate	69370	1
7	Clip Mounting Plate	69374	1
8	Bolt 5/16-18 x 1	35-5-16	4
9	Lockwasher 5/16	17-5C	4
10	Bolt 3/4-10 x 2	35-12-32	8
11	Lockwasher 3/4	17-12C	8
12	Nut 3/4-10	22-12	8
16	Bumpers (optional)	PA7344	2

ITEM	SPEED	MAX. SPAN	PART NO.
16	50 & 75 FPM	50 Ft.	PA7344
	110 FPM	35 Ft.	PA7344
	110 FPM	50 Ft.	PA7345

OTHER CRANE COMPONENTS AVAILABLE FROM ACCU

DRIVE UNITS — No. 1 Flange Mounted Reducers, Motors, and Brake Assemblies.
For crane speeds of 50, 75, and 110 FPM.

HAND GEARED KITS — Hand Drive Assemblies with Handwheel and Guard.

SHAFT COUPLING KIT
For 1¼" shafts.

SHAFT SUPPORT KITS
For 1¼" shafts.

BUMPER KITS — See page 3.
Required by ASME B30.17 for power-driven cranes.

CAPACITY PLATES — See page 3.
Required by ASME B30.17. Capacity plates should be visible from the ground or floor.

ELECTRICAL CONTROLS
Prewired bridge motion controls for power supplies of 200, 230, 460, or 575 volts.
Options: ACM (Acceleration Control Module)
Single, two, or inverter controlled speeds
Magnetic mainline contactor
Ballast resistors

BRIDGE AND RUNWAY ELECTRIFICATION

TRAVELING PUSHBUTTON KIT

FUSIBLE MANUAL DISCONNECT SWITCH

NOTES

GENERAL CONDITIONS OF WARRANTY

WARRANTIES: The Seller warrants to the original using Buyer thereof that the goods sold under this Agreement are free from defects in workmanship and materials for a period of one year from the date of shipment to the original using Buyer. No other express warranties are given and no affirmation of Seller or Seller's agents, by word or action, shall constitute a warranty. No warranty is made for components and accessories made by others when such items are warranted by their respective manufacturers.

Installation or operation of the equipment in any manner other than as recommended by Seller, shall void the warranty. Any variations in details between the goods furnished herein and those covered in Buyer's specifications are due to standards of manufacture not to be construed as exceptions to the specifications.

DISCLAIMER OF IMPLIED WARRANTIES:

- (a) SELLER MAKES NO WARRANTY OF MERCHANTABILITY IN RESPECT TO THE GOODS SOLD UNDER THIS AGREEMENT.
- (b) This sale is made WITHOUT ANY WARRANTY BY SELLER THAT THE GOODS ARE SUITABLE FOR ANY PARTICULAR PURPOSE.
- (c) Buyer hereby waives all other warranties, guarantees, obligations, liabilities, rights and remedies arising by law or otherwise including any obligation or liability of the Seller arising from tort, and Buyer shall indemnify Seller from any liability, loss, damage, or claim arising from Buyer's tortious use of the goods sold hereby.

REMEDIES:

- (a) Under no conditions shall any goods be returned to Seller without its prior written consent.
- (b) The Buyer's sole and exclusive remedy for breach of any warranty is limited to Seller furnishing at its expense duplicate or repaired parts f.o.b. Seller's plant with installation at Buyer's expense if discovery of a claimed defect occurs during the allowable warranty period, and if Seller's inspection determines a defect exists.
- (c) The quantity of material shown by invoice shall in all cases govern settlement for shortages, unless notice of shortage, appropriately documented, is given to the carrier and the Seller upon delivery by the carrier.
- (d) Claims for errors, deficiencies or imperfections shall be deemed waived by the Buyer unless Seller is notified in writing of the basis of such claims within 10 days after discovery of claimed defect and such discovery occurs within the warranted period.
- (e) Neither Buyer nor user shall be entitled under this Agreement to recover from Seller any incidental or consequential damages of any nature including but not limited to the cost of any labor expended by others in connection with the goods sold hereby by reason of any alleged nonconformity or breach of warranty on the part of the Seller nor costs of material or account thereof, nor any lost profits whether determinable or speculative.



Acco Chain & Lifting Products Division

76 Acco Drive, Box 792, York, PA 17405
717 741-4863 Fax 717 741-8572

© Babcock Industries Inc. 1993
Printed in U.S.A.